

Description

The DC1524D3 is designed for asymmetrical (15V to -24V) protection in multi-point data transmission application, making this device an ideal solution for protecting voltage sensitive high-speed data lines. The DC1524D3 complies with the IEC 61000-4-2 (ESD) with $\pm 30\text{kV}$ air and $\pm 30\text{kV}$ contact discharge. It is assembled into a lead-free SOD-323 package. The small size, low capacitance and high ESD surge protection make DC1524D3 an ideal choice to protect one data line of the Local information Network (LIN) in an automotive.

Mechanical Characteristics

- ◆ Package: SOD-323
- ◆ Lead Finish: Matte Tin
- ◆ Case Material: "Green" Molding Compound.
- ◆ Moisture Sensitivity: Level 3 per J-STD-020
- ◆ Terminal Connections: See Diagram Below
- ◆ Marking Information: See Below

Dimensions and Pin Configuration

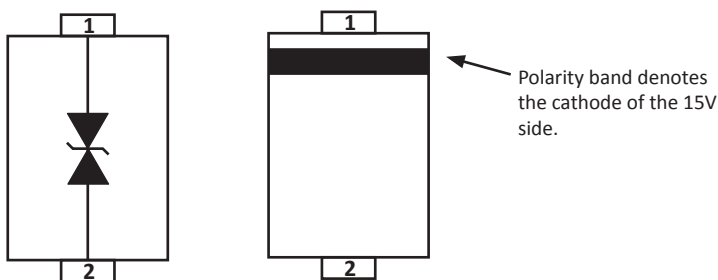

Circuit and Pin Schematic

Features

- ◆ 160W peak pulse power (8/20 μs)
- ◆ Low Channel input capacitance
- ◆ Ultra low leakage: nA level
- ◆ Low clamping voltage
- ◆ Protects one data line of the LIN
- ◆ Complies with following standards:
 - IEC 61000-4-2 (ESD) immunity test
 - Air discharge: $\pm 30\text{kV}$
 - Contact discharge: $\pm 30\text{kV}$
- ◆ RoHS Compliant

Applications

- ◆ LIN Bus Protection

Marking Information



54 = Device Marking Code

Ordering Information

Part Number	Marking	Packaging	Reel Size
DC1524D3	54	3000/Tape & Reel	7 inch

Absolute Maximum Ratings ($T_A=25^{\circ}\text{C}$ unless otherwise specified)

Parameter	Symbol	Value	Unit
Peak Pulse Power (8/20 μs)	Ppk	160	W
Peak Pulse Current ($t_p = 8/20\mu\text{s}$), Pin 1 to Pin 2	Ipp	5	A
Peak Pulse Current ($t_p = 8/20\mu\text{s}$), Pin 2 to Pin 1		3	
ESD per IEC 61000-4-2 (Air)	VESD	± 30	kV
ESD per IEC 61000-4-2 (Contact)		± 30	
Operating Temperature Range	TJ	-40 to +85	$^{\circ}\text{C}$
Storage Temperature Range	Tstg	-55 to +150	$^{\circ}\text{C}$

Electrical Characteristics ($T_A=25^{\circ}\text{C}$ unless otherwise specified)

Parameter	Symbol	Pin 1 to 2 (15V TVS)			Pin 2 to 1 (24V TVS)			Unit	Test Condition
		Min	Typ	Max	Min	Typ	Max		
Reverse Working Voltage	VRWM			15			24	V	
Breakdown Voltage	VBR	17.1			25.4			V	$I_T = 1\text{mA}$
Reverse Leakage Current	IR			50			50	nA	$V_R = V_{RWM}$
Clamping Voltage	VC			25			35	V	$I_{PP} = 1\text{A}$ (8 x 20 μs pulse)
Clamping Voltage	VC						50	V	$I_{PP} = 3\text{A}$ (8 x 20 μs pulse)
Clamping Voltage	VC			35				V	$I_{PP} = 5\text{A}$ (8 x 20 μs pulse)
Junction Capacitance	CJ			13			13	pF	$V_R = 0\text{V}$, $f = 1\text{MHz}$
Junction Capacitance	CJ			10			8	pF	$V_R = V_{RWM}$, $f = 1\text{MHz}$

Typical Performance Characteristics (TA=25°C unless otherwise Specified)

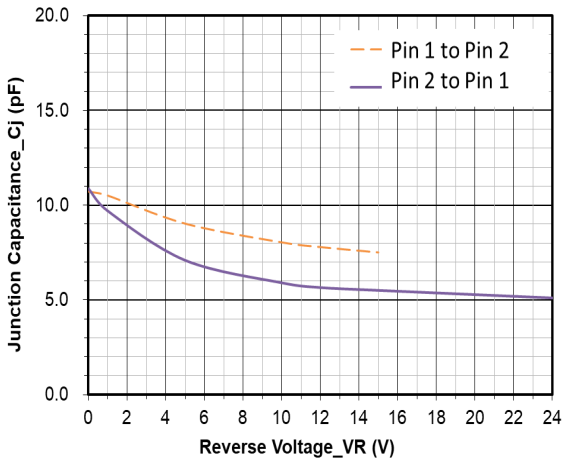

Junction Capacitance vs. Reverse Voltage

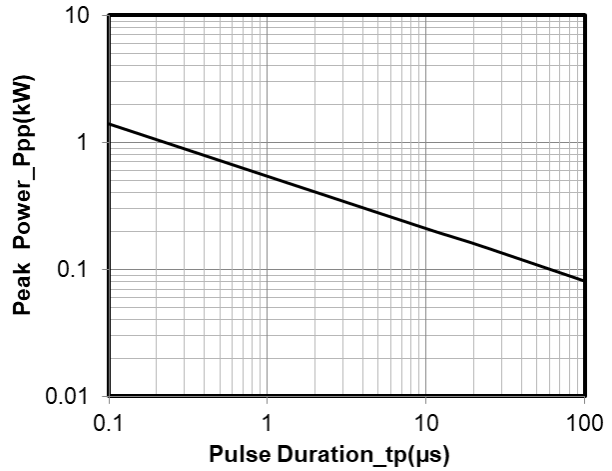

Peak Pulse Power vs. Pulse Time

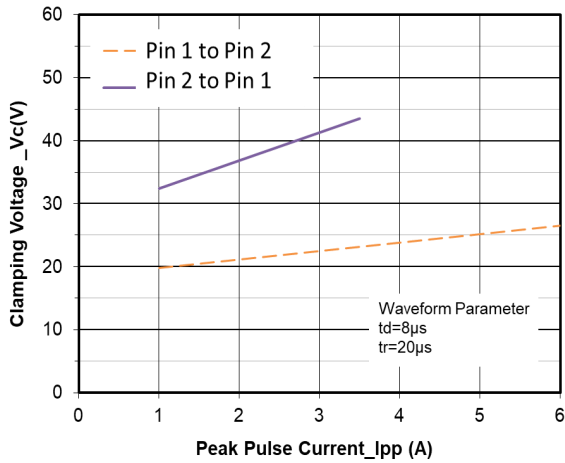

Clamping Voltage vs. Peak Pulse Current

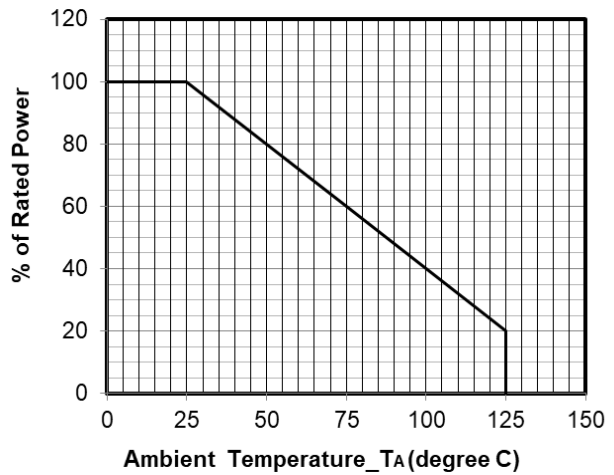

Power Derating Curve

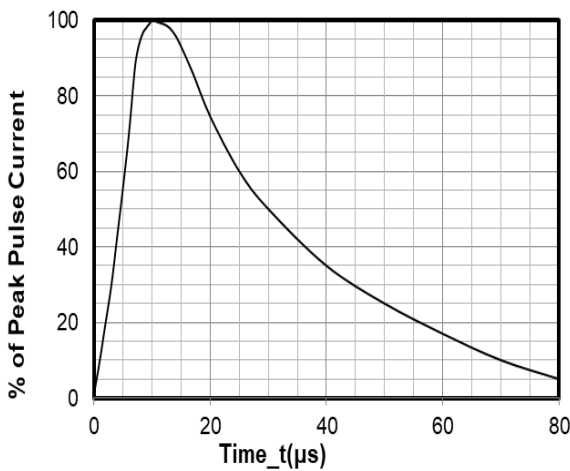

8 X 20μs Pulse Waveform

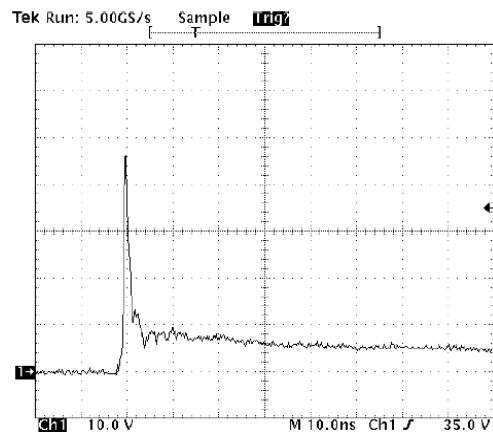

Note: Data is taken with a 10x attenuator

**ESD Clamping Voltage
8 kV Contact per IEC61000-4-2**

SOD-323 Package Outline Drawing

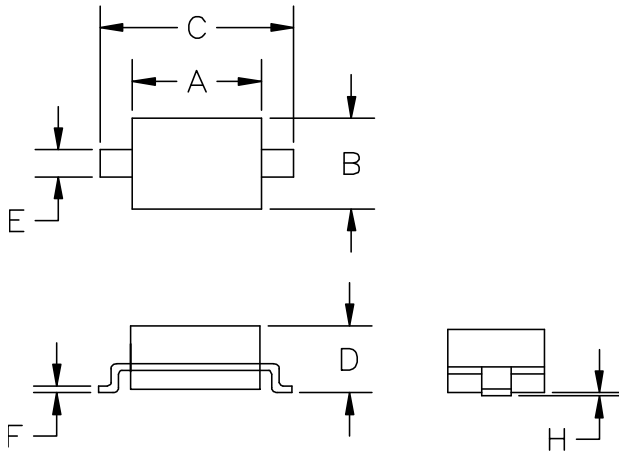

SYM	DIMENSIONS			
	MILLIMETERS		INCHES	
	MIN	MAX	MIN	MAX
A	1.50	1.80	0.060	0.071
B	1.20	1.40	0.045	0.054
C	2.30	2.70	0.090	0.107
D	-	1.10	-	0.043
E	0.30	0.40	0.012	0.016
F	0.10	0.25	0.004	0.010
H	-	0.10	-	0.004

Suggested Land Pattern



SYM	DIMENSIONS	
	MILLIMETERS	INCHES
A	3.15	0.120
B	0.80	0.031
C	0.80	0.031

Contact Information

Changzhou D-first Electronics CO.,Ltd.

www.first-electronic.com

Email: xhf@first-electronic.cn

Phone: +86 (0519) 88171671